

BACKLASH FREE AND STANDARD JAW COUPLING

Up to 9.600 Nm of torque and 130 mm bore

GAS/SG e GAS



ComInTec[®]
Technology for Safety

GAS/SG-ST - backlash free jaw coupling «in steel»: introduction



- Made in steel fully turned with standard phosphating treatment.
- Several elastomer hardnesses available (page 27).
- High torsional rigidity.
- Electric insulation between the parts.
- Statically balanced.
- Version with integrated locking assemblies (GAS/SG/CCE page 29).

ON REQUEST

- Conformity to directive ATEX possible.
- Specific surface treatments or fully stainless steel version.
- Customized manufacturing for specific requirements.
- Connection to the Torque limiter's (safety coupling) range possible.

The coupling GAS/SG is an elastomeric coupling with compact dimensions composed of two hubs made in steel UNI EN10083/98, fully turned and one elastomeric element.

The hub's tooth profile is designed to allow the elastomeric element to work only by compression and not in shear, allowing for a longer life of the coupling in high reversal or load applications.

The presence of the elastomer assures:

- the possibility to absorb collisions and vibrations;
- to compensate for unavoidable misalignments between the shafts;
- silence during transmission.

The basic series of GAS/SG is composed of different details that can be assembled together in order to get the right configuration for the application:

- **Hub 1 (M1):** hub base for any type of connection
- **Long hub 1 (M1L):** extended hub for connecting long shafts
- **Hub 2 (M2):** hub with external diameter lowered for assembly in confined spaces

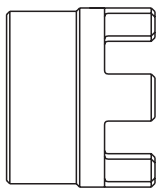

Hub M1

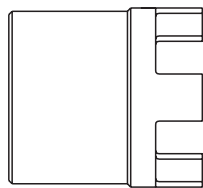

Hub M1L

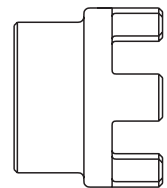

Hub M2

DESCRIPTION OF THE ELASTOMERIC ELEMENT

The fundamental item of this coupling is the elastomeric element or elastomer, made in polyurethane and available in several hardness grades, for different uses and applications. The elastomer is manufactured to resist ageing, scoring, fatigue, hydrolysis and UV radiations, promoting longer life operation. It also resists main chemical agents, like ozone, oils, grease and hydrocarbons.

The elastomeric element becomes prestressed during the assembly between the relevant hub's teeth, in order to be able to transmit the motion without backlash, so torsionally rigid inside the prestressing load. The prestressed elastomer's surface is sufficiently wide to induce a low contact pressure on the tooth of the same elastomer, reducing permanent deformations and promoting a long life.

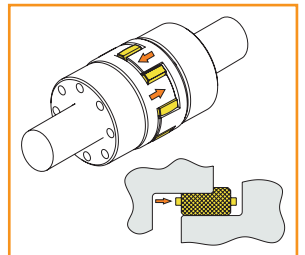

ATEX CONFORMITY



The GAS/SG coupling can be supplied in accordance to directive 94/9/CE ATEX, which is relevant to protection apparatus and systems for use in potentially explosive spaces.

The dimensions of this coupling's version are not different from the standard version.



A mark relevant to the coupling's performances is printed on the hubs. It is necessary to consider planned tests, like those in the use and maintenance manual supplied together with each ATEX coupling.

The elastomeric elements used can be:

- red elastic element in polyurethane, 98 Shore-A : II 2 G D c T6 -20≤Ta≤+60°C X U
- yellow elastic element in polyurethane, 92 Shore-A : II 2 G D c T5 -20≤Ta≤+80°C X U

GAS/SG-ST - backlash free jaw coupling «in steel»: introduction

SG ELASTIC ELEMENT: PHYSICAL CHARACTERISTICS

Hardness	Material	Spider	Allowed temperature [°C]		Uses
			working	max (for short period)	
92 Sh-A	Polyurethane		-40 ÷ +90	-50 ÷ +120	<ul style="list-style-type: none"> - low and medium power - measurement and control system - common electric motors
98 Sh-A	Polyurethane		-30 ÷ +90	-40 ÷ +120	<ul style="list-style-type: none"> - high transmission torque - actuators, screwjacks - servomotors, right angle gearboxes
64 Sh-D	Polyurethane		-20 ÷ +110	-30 ÷ +120	<ul style="list-style-type: none"> - high torsional rigidity - machining centres - internal combustion motors

SG ELASTOMERIC ELEMENT: TECHNICAL CHARACTERISTICS

Size	Hardness	Torque		Misalignment			Rigidity		
		nom [Nm]	max [Nm]	angular α [°]	axial X [mm]	radial K [mm]	static torsional R _{stat} [Nm/Rad]	dynamic torsional R _{din} [Nm/rad]	radial R _r [N/mm]
04 (7)	92 Sh-A	1,2	2,4	1	0,6	0,1	14,5	43	218
	98 Sh-A	2	4	0,9		0,06	23	69,5	420
	64 Sh-D	2,4	4,8	0,8		0,04	34,7	102,5	630
03 (9)	92 Sh-A	3	6	1	0,8	0,13	31,5	95	270
	98 Sh-A	5	10	0,9		0,08	51,5	155	520
	64 Sh-D	6	12	0,8		0,05	74,5	225	740
01 (14)	92 Sh-A	7,5	15	1°	1	0,14	115	340	330
	98 Sh-A	12,5	25	0° 54'		0,09	170	510	605
	64 Sh-D	16	32	0° 48'		0,06	235	700	855
00 (19)	92 Sh-A	10	20	1°	1,2	0,10	815	1900	1250
	98 Sh-A	17	34	0° 54'		0,06	980	2340	2000
	64 Sh-D	21	42	0° 48'		0,04	1450	4450	2950
0 (24)	92 Sh-A	35	70	1°	1,4	0,14	2300	5120	1900
	98 Sh-A	60	120	0° 54'		0,10	3650	8100	2900
	64 Sh-D	75	150	0° 48'		0,07	4500	11500	4180
1 (28)	92 Sh-A	95	190	1°	1,5	0,15	3810	7280	2100
	98 Sh-A	160	320	0° 54'		0,11	4180	10700	3650
	64 Sh-D	200	400	0° 48'		0,08	7350	18500	4880
2 (38)	92 Sh-A	190	380	1°	1,8	0,16	5580	11950	2850
	98 Sh-A	325	650	0° 54'		0,12	8150	21850	5000
	64 Sh-D	405	810	0° 48'		0,09	9920	33600	6200
3 (42)	92 Sh-A	265	530	1°	2	0,18	9800	20400	4050
	98 Sh-A	450	900	0° 54'		0,15	15000	34000	5900
	64 Sh-D	560	1120	0° 48'		0,10	16000	71300	7570
4 (48)	92 Sh-A	310	620	1°	2,1	0,22	11500	22000	4400
	98 Sh-A	525	1050	0° 54'		0,16	16000	49000	6800
	64 Sh-D	655	1310	0° 48'		0,11	31000	100000	8900
5 (55)	92 Sh-A	410	820	1°	2,2	0,24	12000	22500	3100
	98 Sh-A	685	1370	0° 54'		0,17	24200	62500	7150
	64 Sh-D	825	1650	0° 48'		0,12	42000	111000	9850
6 (65)	92 Sh-A	900	1800	1°	2,6	0,25	38000	97000	6400
	98 Sh-A	1040	2080	0° 54'		0,18	39000	98500	6650

■ Only for GAS/SG-AL version (page 33)

GAS/SG-ST - backlash free jaw coupling «in steel»: technical data

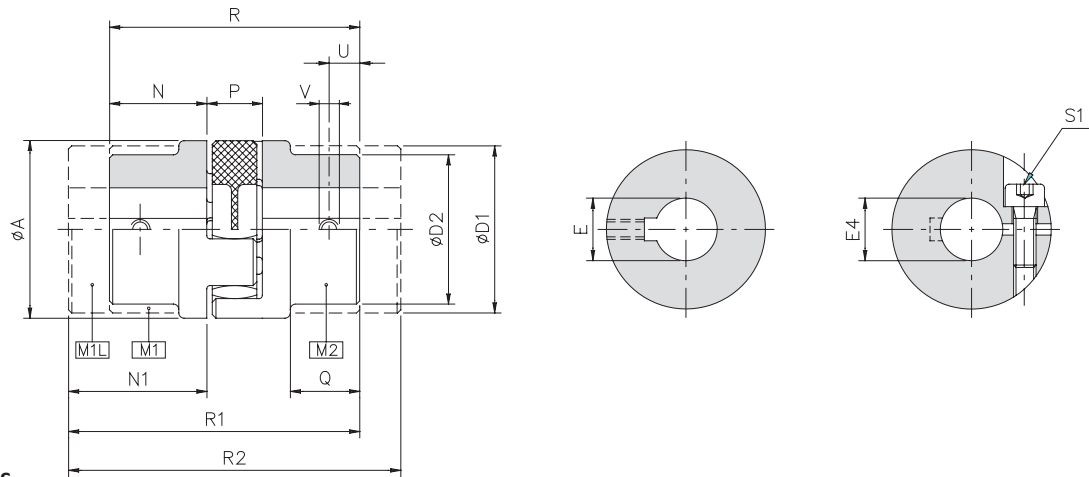

DIMENSIONS

Size	A	D1	D2	EH7 max		E4 H7 max	N	N1	P	Q	R	R1	R2	U	V
				M1	M2	M1									
01 (14)	30	30	-	16	-	15	11	19	13	-	35	42.5	50	5	M4
00 (19)	40	40	32	25	20	20	25	37	16	16,5	66	78	90	10	M5
0 (24)	55	53	40	35	26	30	30	50	18	20	78	98	118	10	M5
1 (28)	65	63	48	40	32	35	35	60	20	24	90	115	140	15	M8
2 (38)	80	78	66	48	44	45	45	70	24	33	114	139	164	15	M8
3 (42)	95	93	75	55	50	50	50	75	26	38	126	151	176	20	M8
4 (48)	105	103	85	62	56	60	56	80	28	45	140	164	188	20	M8
5 (55)	120	118	98	74	65	65	65	90	30	49	160	185	210	20	M10
6 (65)	135	133	115	80	80	70	75	100	35	61	185	210	235	20	M10

TECHNICAL CHARACTERISTICS

Size	Torque [Nm]	Weight [Kg]				Inertia [kgm ²]				Max speed [Rpm]	Clamp hub	
		M1	M1L	M2	Stella	M1	M1L	M2	Stella		Screw S1	Tightening torque S1 [Nm]
01 (14)	See table of page 27	0,06	0,1	-	0,005	0,00001	0,00001	-	0,0000005	25000	M4	4,4
00 (19)		0,2	0,3	0,2	0,009	0,00005	0,00007	0,00003	0,0000015	19000	M5	8,7
0 (24)		0,4	0,8	0,3	0,020	0,00020	0,00029	0,00014	0,0000080	13500	M6	15
1 (28)		0,7	1,3	0,5	0,030	0,00042	0,00066	0,00027	0,0000180	11800	M8	36
2 (38)		1,3	2,2	1,1	0,060	0,00131	0,00189	0,00091	0,0000500	9500	M8	36
3 (42)		1,9	3,2	1,8	0,098	0,00292	0,00411	0,00178	0,0001000	8000	M10	70
4 (48)		2,8	4,4	2,4	0,105	0,00483	0,00653	0,00297	0,0002000	7100	M12	121
5 (55)		4,0	6,1	3,8	0,150	0,00825	0,01125	0,00505	0,0003000	6300	M12	121
6 (65)		5,9	8,6	4,6	0,200	0,01682	0,02175	0,01037	0,0005000	5600	M12	121

TORQUE PERMISSIBLE WITH HUB CONNECTION TYPE B

Torque transmitted [Nm] according to the ϕ finished bore [mm]																													
Grand.	6	8	10	11	12	14	15	16	18	19	20	22	24	25	28	30	32	35	38	40	42	45	48	50	55	60	65	70	
01 (14)	21	22	23	24	25	26	27																						
00 (19)			46	47	48	50	52	53	55	56	58																		
0 (24)				76	78	80	81	84	85	87	89	92	93	97	100														
1 (28)								165	167	170	175	179	182	189	194	199	207												
2 (38)										199	204	209	212	219	224	229	237	244	249	254	262								
3 (42)													320	330	337	343	353	363	370	376	386	396	403						
4 (48)																	1408	1445	1469	1494	1530	1567	1592	1653	1714				
5 (55)																				1640	1677	1714	1738	1800	1861	1922			
6 (65)																					1824	1861	1885	1947	2008	2069	2130		

NOTES

- The weights refer to the coupling with minimum bore.
- Inertias refer to the coupling with maximum bore.
- For choice and availability of different hub connection type see pages 4 and 5.

GAS/SG/CCE-ST - backlash free jaw coupling with external locking assembly «in steel»: technical data

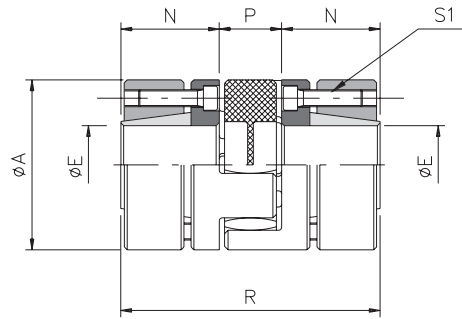

DIMENSIONS

Size	A	EH7		N	P	R
		min	max			
01 (14)	30	6	16	11	13	35
00 (19)	40	10	20	25	16	66
0 (24)	55	15	28	30	18	78
1 (28)	65	19	38	35	20	90
2 (38)	80	20	48	45	24	114
3 (42)	95	28	55	50	26	126
4 (48)	105	35	62	56	28	140
5 (55)	120	35	70	65	30	160
6 (65)	135	40	75	75	35	185

TECHNICAL CHARACTERISTICS

Size	Torque [Nm]	Weight [Kg]		Inertia [Kgm ²]		Max speed [Rpm]	Clamp hub	
		M1	Spider	M1	Spider		Screw S1 UNI 5931	Tightening torque S1 [Nm]
01 (14)		0,06	0,005	0,00001	0,0000005	25000	N°4 x M2,5	0,75
00 (19)		0,20	0,009	0,00005	0,0000030	19000	N°6 x M4	3
0 (24)		0,40	0,020	0,00020	0,0000100	13500	N°4 x M5	6
1 (28)		0,70	0,030	0,00042	0,0000200	11800	N°8 x M5	6
2 (38)		1,30	0,060	0,00131	0,0000500	9500	N°8 x M6	10
3 (42)		1,90	0,098	0,00292	0,0001000	8000	N°4 x M8	35
4 (48)		2,80	0,105	0,00483	0,0002000	7100	N°4 x M8	35
5 (55)		4,00	0,150	0,00825	0,0003000	6300	N°4 x M10	69
6 (65)		5,90	0,200	0,01682	0,0005000	5600	N°4 x M12	120

TORQUE PERMISSIBLE WITH EXTERNAL LOCKING ASSEMBLY TYPE D

Torque transmitted [Nm] according to the ϕ finished bore [mm]																													
Grand.	6	10	11	14	15	16	17	18	19	20	22	24	25	28	30	32	35	38	40	42	45	48	50	55	60	65	70	75	
01 (14)	7	12	13	17	18	20																							
00 (19)		48	53	67	72	77	81	86	91	96																			
0 (24)					77	82	88	93	98	103	113	124	129	144															
1 (28)								186	196	206	227	247	258	289	309	330	361	392											
2 (38)											291	320	349	364	408	437	466	510	553	582	612	655	699						
3 (42)														485	545	584	623	681	740	779	818	876	934	973	1071				
4 (48)															584	623	681	740	779	818	876	934	973	1071	1168				
5 (55)																	1091	1184	1247	1309	1402	1496	1558	1714	1870	2026	2182		
6 (65)																			1852	1944	2083	2222	2315	2546	2778	3009	3241	3472	

NOTES

- The weights refer to the coupling with minimum bore.
- Inertias refer to the coupling with maximum bore.
- For choice and availability of different hub connection type see pages 4 and 5.

GAS-ST - standard jaw coupling «in steel»: introduction



- Made in steel fully turned with standard phosphating treatment.
- Several elastomer hardnesses available (page 31).
- High compensation of misalignments.
- Vibration dampening.
- Statically balanced.
- Modularity of the components, with different assembly versions.

ON REQUEST

- Conformity to ATEX directive possible.
- Specific treatments or version fully in stainless steel.
- Manufacturing made to length and customizations for specific needs.
- Connection to the Torque limiter's (safety coupling) range possible.

The coupling GAS/SG is an elastomeric coupling with compact dimensions composed of two hubs made in steel UNI EN10083/98, fully turned with one elastomer.

The hub's tooth profile is designed to allow the elastomeric element to work only by compression and not in shear, allowing for long life of the coupling in high reversal or load applications.

The GAS base series are available in several hub versions to allow an assembly to suit the application.

- **Hub 1 (M1)** : base hub for any kind of connection.
- **Long hub 1 (M1L)** : extended hub to connect long shafts.
- **Hub 2 (M2)** : hub with reduced external diameter for assembly in compact spaces.
- **Flangie (F)** : flange for connection shaft-flange.

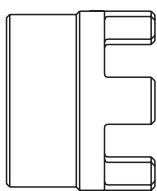

Hub M1

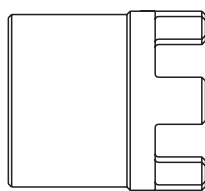

Hub M1L

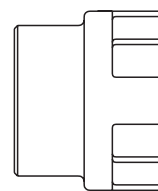

Hub M2

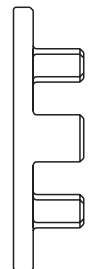

Flangie F

DESCRIPTION OF THE ELASTOMERIC ELEMENT

The fundamental item of this coupling is the elastomeric element, made in different grades of hardness for different needs and applications. The elastomer is manufactured from elements to resist ageing, scoring, fatigue, hydrolysis and UV radiations, promoting long life operation and resisting main chemical agents, like ozone, oils, greases and hydrocarbons.

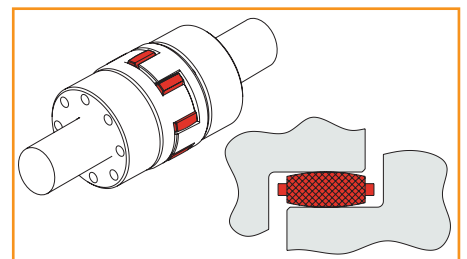

ATEX CONFORMITY



The GAS/SG coupling can be supplied in accordance to ATEX 94/9/CE directive, which is relevant to protection apparatus and systems for use in potentially explosive spaces.

The dimensions of this coupling's version are not different from the standard version.



A mark relevant to the coupling's performances is printed on the hubs. It is necessary to consider planned tests, as described in the use and maintenance manual supplied together with each ATEX coupling.

The elastomeric elements used can be:

- yellow elastic element in polyurethane, 92 Shore-A : II 2 G D c T5 -20≤Ta≤+80°C X U

GAS-ST - standard jaw coupling «in steel»: introduction

SG ELASTIC ELEMENT: PHYSICAL CHARACTERISTICS

Hardness	Material	Spider	Allowed temperature [°C]		Users
			working	max (for short periods)	
92 Sh-A	Polyurethane		-40 ÷ +90	-50 ÷ +120	- low and medium power - systems with frequent starts
95 Sh-A 98 Sh-A	Thermoplastic		-40 ÷ +125	-50 ÷ +150	- high transmission torque - high temperature range
64 Sh-D	Polyurethane		-20 ÷ +110	-30 ÷ +120	- high torsional rigidity - Internal combustion motors

SG ELASTIC ELEMENT: TECHNICAL CHARACTERISTICS

Size	Hardness	Torque			Misalignments			Rigidity R_t [10^3 Nm/rad]			
		nom [Nm]	max [Nm]	alternate motion [Nm]	Angular α [°]	Axial x [mm]	Radial k [mm]	25% nom torque	50% nom torque	75% nom torque	100% nom torque
00 (19)	92 Sh-A	10	20	2,6	1° 18'	1,0	0,20	0,62	0,73	0,93	1,18
	98 Sh-A	17	34	4,4				0,92	1,14	1,33	1,49
	64 Sh-D	21	42	5,5				1,97	3,33	4,40	5,37
0 (24)	92 Sh-A	35	70	9	1° 18'	1,0	0,22	2,44	2,71	3,66	4,43
	98 Sh-A	60	120	16				3,64	4,74	5,47	5,92
	64 Sh-D	75	150	19,5				5,50	9,35	12,40	15,10
1 (28)	92 Sh-A	95	190	25	1° 18'	1,2	0,25	4,10	5,73	6,62	7,65
	98 Sh-A	160	320	42				6,08	7,82	8,88	10,68
	64 Sh-D	200	400	52				10,10	17,00	22,55	27,50
2 (38)	92 Sh-A	190	380	49	1° 18'	1,4	0,28	8,69	10,75	12,55	14,57
	98 Sh-A	325	650	85				10,95	14,13	18,25	21,90
	64 Sh-D	405	810	105				25,75	43,50	57,50	70,10
3 (42)	92 Sh-A	265	530	69	1° 18'	1,6	0,32	11,52	14,66	17,27	21,50
	98 Sh-A	450	900	117				16,34	21,41	25,17	30,29
	64 Sh-D	560	1120	145				29,30	49,50	65,45	79,85
4 (48)	92 Sh-A	310	620	81	1° 18'	1,7	0,36	11,85	18,72	21,34	24,52
	98 Sh-A	525	1050	137				17,97	24,39	27,68	34,14
	64 Sh-D	655	1310	170				35,10	59,20	78,30	95,50
5 (55)	92 Sh-A	410	820	105	1° 18'	1,8	0,38	16,63	26,27	29,94	34,42
	98 Sh-A	685	1370	178				24,88	33,77	38,33	47,27
	64 Sh-D	825	1650	215				39,65	66,90	88,55	107,90
6 (65)	92 Sh-A	625	1250	163	1° 18'	2,0	0,42	27,14	38,00	40,71	50,67
	98 Sh-A	940	1880	245				36,00	48,01	55,55	66,47
	64 Sh-D	1175	2350	305				55,54	93,65	124,00	150,10
7 (75)	92 Sh-A	975	1950	254	1° 18'	2,5	0,48	54,17	70,10	89,38	103,63
	98 Sh-A	1465	2930	381				72,52	92,30	112,81	123,07
	64 Sh-D	2410	4820	625				91,21	153,87	203,51	249,12
8 (90)	92 Sh-A	2400	4800	624	1° 18'	2,8	0,50	88,99	113,90	164,29	177,98
	98 Sh-A	3600	7200	936				127,47	172,99	201,82	230,65
	64 Sh-D	4500	9000	1170				246,85	415,53	550,13	672,87
9 (100)	95 Sh-A	3300	6600	858	1° 18'	3,0	0,52	95,09	157,88	210,55	255,82
10 (110)	95 Sh-A	4800	9600	1248	1° 18'	3,2	0,55	115,44	195,24	256,41	315,42

GAS-ST - standard jaw coupling «in steel»: technical data

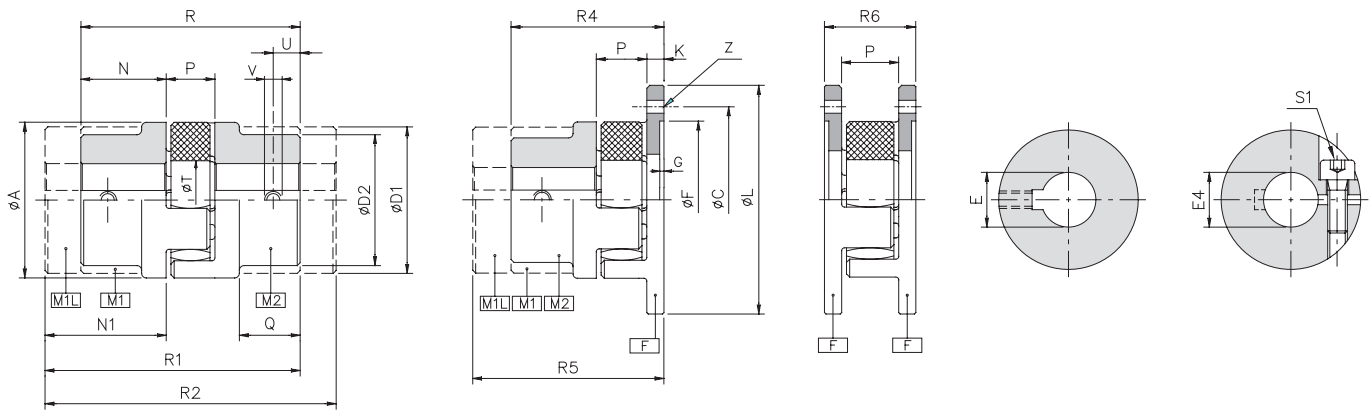

DIMENSIONS

Size	A	C	D1	D2	E H7 max		E4 H7 max	F	G	L	K	N	N1	P	Q	R	R1	R2	R4	R5	R6	T	U	V	Z
					M1	M2																			
00 (19)	40	50	40	32	25	20	20	40	1,5	58	8	25	37	16	16,5	66	78	90	49	61	32	18	10	M5	n.5 x ø4,5
0 (24)	55	65	53	40	35	26	30	55	1,5	74	8	30	50	18	20	78	98	118	56	76	34	27	10	M5	n.5 x ø4,5
1 (28)	65	80	63	48	40	32	35	65	1,5	92	10	35	60	24	24	90	115	140	65	90	40	30	15	M8	n.6 x ø6,6
2 (38)	80	95	78	66	48	44	45	80	1,5	107	10	45	70	24	33	114	139	164	79	104	44	38	15	M8	n.6 x ø6,6
3 (42)	95	115	93	75	55	50	50	95	2	132	12	50	75	26	38	126	151	176	88	113	50	46	20	M8	n.6 x ø9
4 (48)	105	125	103	85	62	56	60	105	2	142	12	56	80	28	45	140	164	188	96	120	52	51	20	M8	n.8 x ø9
5 (55)	120	145	118	98	74	65	65	120	2	164	16	65	90	30	49	160	185	210	111	136	62	60	20	M10	n.8 x ø11
6 (65)	135	160	133	115	80	80	70	135	2	179	16	75	100	35	61	185	210	235	126	151	67	68	20	M10	n.10 x ø11
7 (75)	160	185	158	135	95	95	-	160	2,5	215	19	85	110	40	69	210	235	260	144	169	78	80	25	M10	n.10 x ø14
8 (90)	200	225	180	160	110	110	-	200	3	246	20	100	125	45	81	245	270	295	165	190	85	100	30	M12	n.12 x ø14
9 (100)	225	250	-	180	-	120	-	225	4	285	25	110	-	50	89	270	-	-	185	-	100	113	30	M12	n.12 x ø14
10 (110)	255	290	-	200	-	130	-	255	4	330	26	120	-	55	96	295	-	-	201	-	157	127	35	M16	n.12 x ø18

TECHNICAL CHARACTERISTICS

Size	Torque [Nm]	Weight [Kg]					Inertia [Kgm ²]					Max speed [Rpm]	Clamp hub	
		M1	M1L	M2	F	Stella	M1	M1L	M2	F	Stella		Screw S1	Tightening torque S1 [Nm]
00 (19)	See table at page 31	0,2	0,3	0,2	0,1	0,009	0,00005	0,00007	0,00003	0,00007	0,000003	19000	M5	10,5
0 (24)		0,4	0,8	0,3	0,3	0,020	0,00020	0,00029	0,00010	0,00014	0,000010	13500	M6	17,5
1 (28)		0,7	1,3	0,5	0,6	0,030	0,00042	0,00066	0,00022	0,00044	0,000020	11800	M8	28
2 (38)		1,3	2,2	1,1	0,9	0,060	0,00131	0,00189	0,00089	0,00121	0,000050	9500	M8	28
3 (42)		1,9	3,2	1,8	1,6	0,098	0,00292	0,00411	0,00232	0,00246	0,000100	8000	M10	84
4 (48)		2,8	4,4	2,4	1,8	0,105	0,00483	0,00653	0,00383	0,00302	0,000200	7100	M12	145
5 (55)		4,0	6,1	3,8	3,0	0,150	0,00825	0,01125	0,00740	0,00740	0,000300	6300	M12	145
6 (65)		5,9	8,6	4,6	3,7	0,200	0,01682	0,02175	0,01087	0,01087	0,000500	5600	M12	145
7 (75)		9,1	13	7,2	5,2	0,380	0,03933	0,04915	0,02393	0,02333	0,002000	4750	-	-
8 (90)		17,0	22	12,5	8,3	0,650	0,10936	0,09293	0,08484	0,06036	0,004000	3750	-	-
9 (100)	-	-	25	10,5	0,850	-	-	0,11450	-	0,006000	3350	-	-	
10 (110)	-	-	35	18,0	1,250	-	-	0,20120	-	0,011000	3000	-	-	

TORQUE PERMISSIBLE WITH HUB CONNECTION TYPE B

Torque transmitted [Nm] according to the ø finished bore [mm]																											
Grand.	10	11	12	14	15	16	18	19	20	22	24	25	28	30	32	35	38	40	42	45	48	50	55	60	65	70	
00	46	47	48	50	52	53	55	56	58																		
0			76	78	80	81	84	85	87	89	92	93	97	100													
1							165	167	170	175	179	182	189	194	199	207											
2									199	204	209	212	219	224	229	237	244	249	254	262							
3												320	330	337	343	353	363	370	376	386	396	403					
4															1408	1445	1469	1494	1530	1567	1592	1653	1714				
5																		1640	1677	1714	1738	1800	1861	1922			
6																			1824	1861	1885	1947	2008	2069	2130		

NOTES

▲ On request

- The weights refer to the coupling with minimum bore.
- Inertias refer to the coupling with maximum bore.
- For choice and availability of different hub connection type see pages 4 and 5.

GAS/SG-AL & GAS-AL - backlash free and standard jaw coupling «in aluminium»: technical data



- Made in aluminum fully turned.
- Elastomer available in different hardness (see pages 24 and 31).
- Weight and inertia reduced.
- Electrical insulation between the parties.
- Statically balanced.
- Modular components with different locking systems on the hubs.

ON REQUEST

- Single split clamp hub with H7 bore and keyway (type B1).
- Two piece clamp hub with H7 bore and keyway (type C1)
- Conformity to Directive ATEX possible.
- Customized manufacturing for specific requirements.

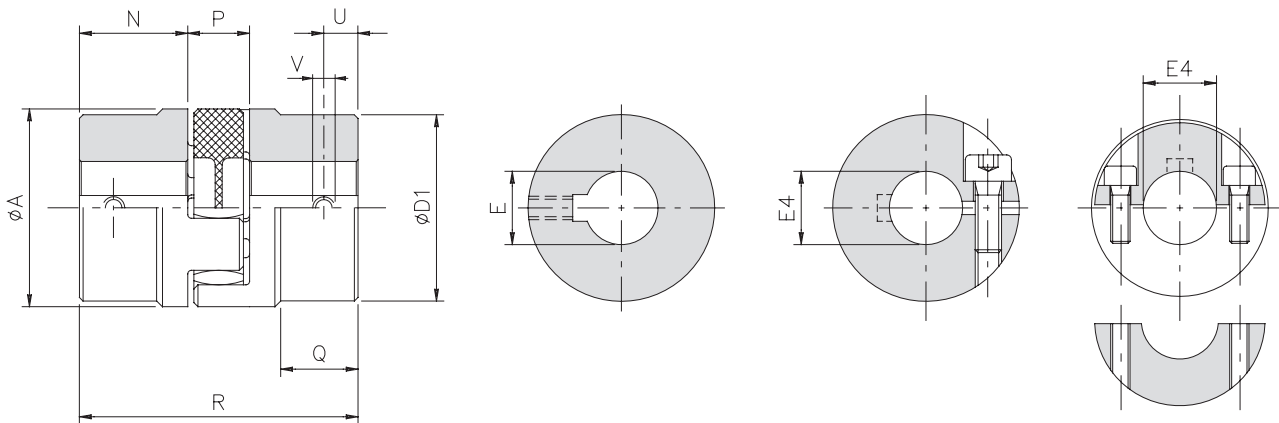

DIMENSIONS

Size	Torque [Nm]	A	D1	EH7 max		N	P	Q	R	U	V	Weight [Kg]		Inertia [10^{-3}Kgm^2]		Max speed [Rpm]	Clamp hub	
				M1	M1							M1	Spider	M1	Spider		Screw	Tightening torque [Nm]
04 (7)	GAS/SG-AL see page 27 GAS-AL see page 31	14	-	7	6	7	8	-	22	3,5	M3	0,003	0,0007	0,000085	0,000015	34000	M2,5	0,8
03 (9)		20	-	9	9	10	10	-	30	4	M4	0,009	0,002	0,000500	0,000080	22000	M3	1,4
01 (14)		30	-	16	15	11,5	12	-	35	5	M4	0,02	0,005	0,002800	0,000500	19000	M4	3,1
00 (19)		40	-	25	20	25	16	-	66	10	M5	0,07	0,009	0,020500	0,001500	14000	M5	6,2
0 (24)		55	53	35	30	30	18	20	78	10	M5	0,13	0,020	0,050000	0,008000	10500	M6	10,5
1 (28)		65	63	40	35	35	20	24	90	15	M8	0,26	0,030	0,200000	0,018000	9000	M8	25
2 (38)		80	78	48	45	45	24	33	114	15	M8	0,46	0,060	0,400000	0,050000	7000	M8	25

TORQUE PERMISSIBLE WITH HUB CONNECTION TYPE B

Size	Torque transmitted [Nm] according to the ϕ finished bore [mm]																								
	3	4	6	8	9	10	11	12	14	15	16	18	19	20	22	24	25	28	30	32	35	38	40	42	45
04 (7)	1,4	1,6	1,8																						
03 (9)		3,1	3,5	3,8	4																				
01 (14)			9	10	10	10,5	11	11,5	12	12,5															
00 (19)						21	21	22	23	24	24	25	26	26											
0 (24)								35	36	37	37	38	39	40	41	42	43	45	46						
1 (28)												80	81	82	84	87	88	92	94	97	100				
2 (38)														97	99	101	103	106	109	111	115	118	121	123	127

NOTES

- The weights refer to the coupling with minimum bore.
- Inertias refer to the coupling with maximum bore.
- For choice and availability of different hub connection type see pages 4 and 5.

GAS/SG/DBSE-AL - backlash free jaw coupling with spacer «in aluminium»: technical data



- Made of aluminum fully turned.
- Elastomer available in different hardness (see pages 25 and 29).
- Simple mounting thanks to the two piece clamp hub (type C).
- Radial assembly without removing the parts.
- Electrical insulation between the parts.
- Spacer with DBSE custom made.

ON REQUEST

- Two piece clamp hub with keyway (C1).
- Various hub connection types available.
- Conformity to Directive ATEX possible.
- Dynamic balancing up to Q=2.5.

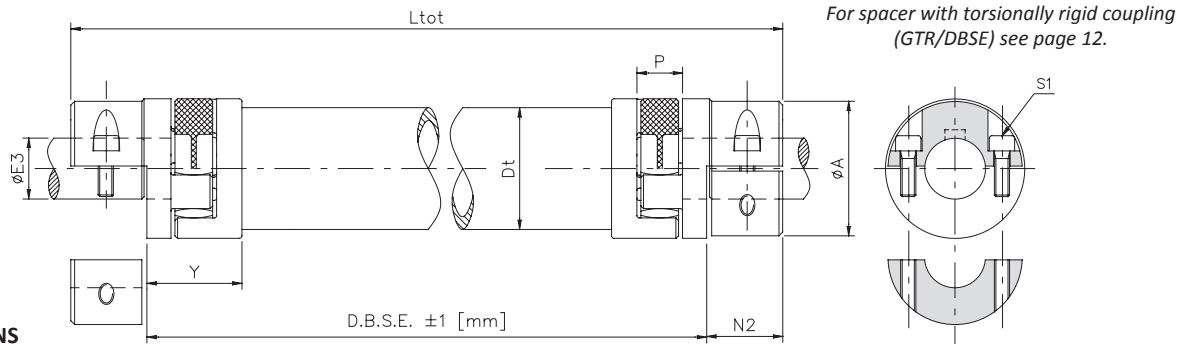

DIMENSIONS

Size	Torque [Nm]	A	E3 H7 max	N2	P	Y	Spacer				Total weight [Kg]	L _{tot} [mm]	E4 H7 max	
							Dt	Weight [Kg/m]	Inertia [10 ⁻³ Kg/m]	Rigidity R _{rel} [10 ³ Nm/rad-m]			DBSE min [mm]	Screw S1
01 (14)	See page 27	30	15	14	12	20,5	30	1,06	0,162	1552	Total weight = 2 • weight [GAS/SG-AL] + spacer weight • (DBSE - 2Y) L _{tot} = DBSE + 2 N2	58	M4	3,1
00 (19)		40	20	19	16	30,5	35	1,27	0,273	2650		95	M5	6,2
0 (24)		55	30	22	18	37,5	50	1,91	0,917	8800		113	M6	10,5
1 (28)		65	35	25	20	41	60	3,34	2,184	21150		131	M8	25
2 (38)		80	45	34	24	46	70	5,09	4,341	42400		161	M8	25

TORQUE PERMISSIBLE WITH HUB CONNECTION TYPE C

Size	Torque transmitted [Nm] according to the Ø finished bore [mm]																					
	6	8	10	11	12	14	15	16	18	19	20	22	24	25	28	30	32	35	38	40	42	45
01 (14)	6	9	11	12	13	15	16															
00 (19)			17	19	21	24	26	28	31	33	35											
0 (24)					24	28	30	32	36	38	40	44	47	49	55	59						
1 (28)									69	73	77	85	92	96	108	115	123	135				
2 (38)											77	85	92	96	108	115	123	135	146	154	162	173

PERMITTED SPEEDS

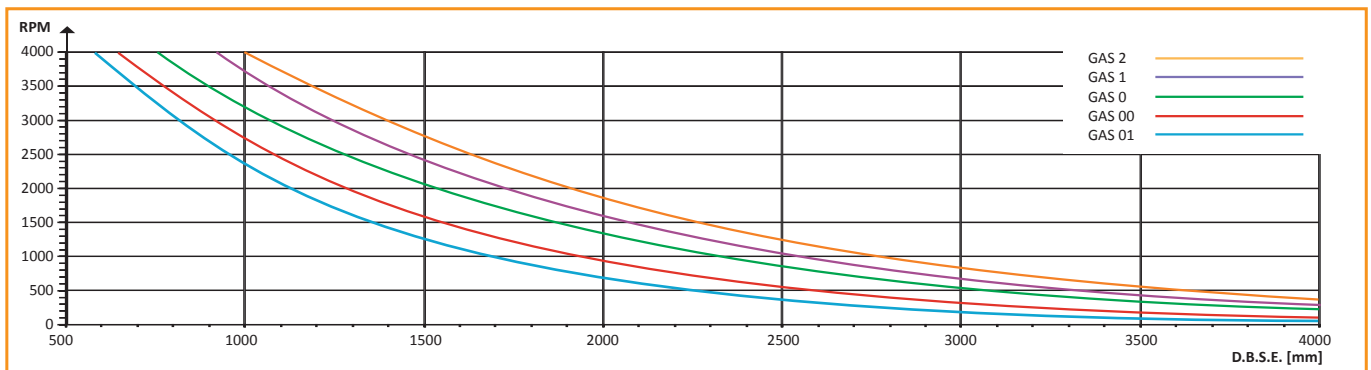

NOTES

- The weights refer to the coupling with minimum bore.
- Inertias refer to the coupling with maximum bore.
- For choice and availability of different hub connection type see pages 4 and 5.

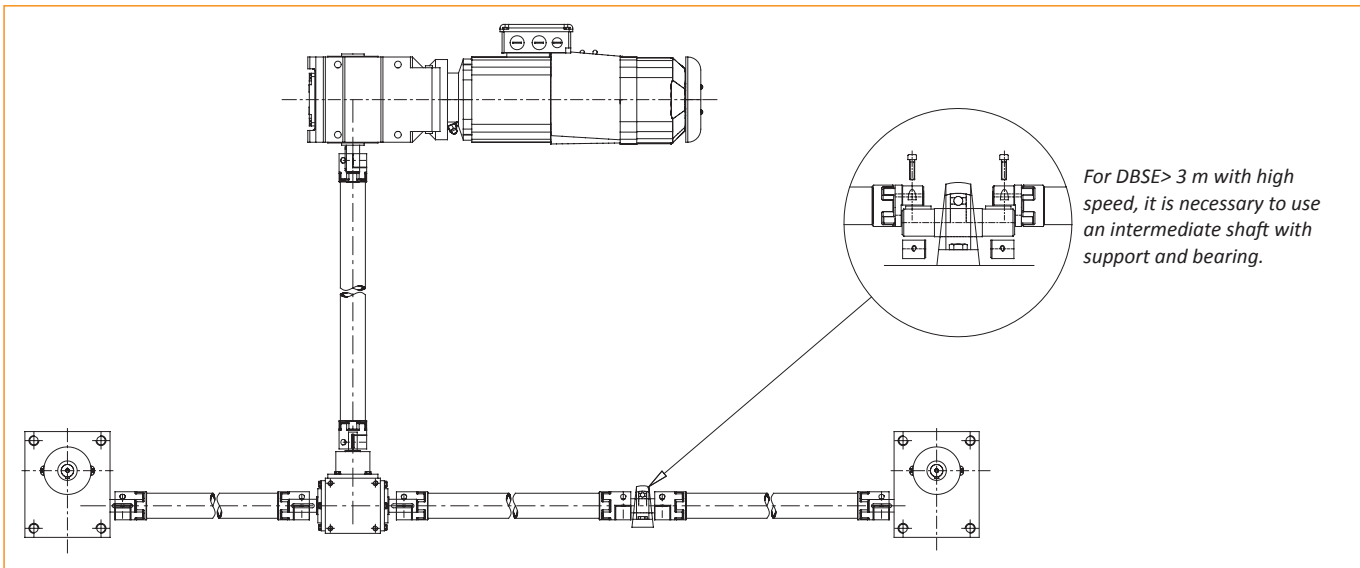

The model with a central spacer "GAS / SG / DBSE-AL", in addition to being essential for connecting transmission drives spaced apart. Is able (unlike the classic model GAS/SG) to recover, as needed, up to twice the angular misalignment (picture 2) and axial (picture 3) or a high radial misalignment (picture 1) according to the formula:

$$K = [L_{tot} - (2 \cdot N) - P] \cdot \text{Tg } \alpha$$

Where:

- K = radial misalignment [mm]
- L_{tot} = total length of GAS/DBSE coupling [mm]
- N = useful length of an half-hub [mm]
- P = useful space of the elastomeric element [mm]
- α = angular misalignment [°]

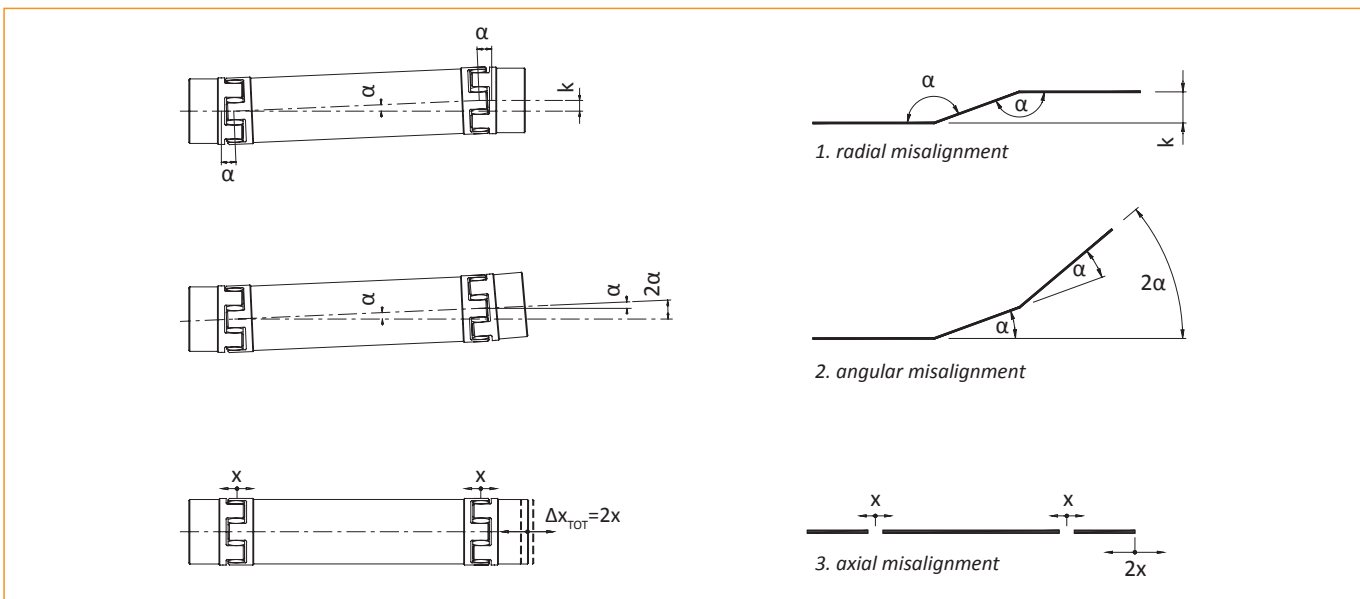

It is possible to determine also the positioning error by the torsion angle according to the formula:

$$\beta = \frac{180 \cdot C_{mot}}{\pi \cdot R_{TOT}}$$

Where:

- β = torsion angle [°]
- C_{mot} = maximum torque motor side [Nm]
- R_{TOT} = total torsional rigidity of the coupling [Nm/rad]

In case of GAS/SG/DBSE-AL the total torsional rigidity of the coupling is expressed by the formula:

$$R_{TOT} = \frac{1}{\left(\frac{2}{R_T} + \frac{L_s}{R_{rel}}\right)}$$

Where:

- R_{TOT} = total torsional rigidity [Nm/rad]
- R_T = torsional rigidity of spider [Nm/rad]
- R_{rel} = torsional rigidity of spacer [Nm/rad]
- L_s = spacer length (=DBSE-2Y) [m]

GAS/SG & GAS - backlash free and standard jaw coupling: selection for motors

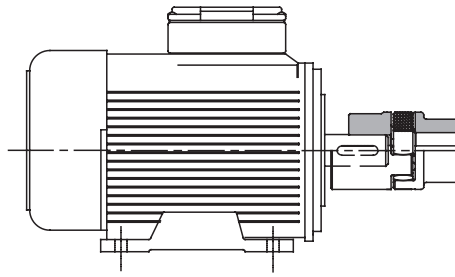

Electric motor		750 Rpm					1000 Rpm					1500 Rpm					3000 Rpm				
Size IEC	Shaft	P [Kw]	C [Nm]	GAS			P [Kw]	C [Nm]	GAS			P [Kw]	C [Nm]	GAS			P [Kw]	C [Nm]	GAS		
				92 Sh-A	98 Sh-A	64 Sh-D			92 Sh-A	98 Sh-A	64 Sh-D			92 Sh-A	98 Sh-A	64 Sh-D			92 Sh-A	98 Sh-A	64 Sh-D
56	Ø9x20	-	-	-	-	-	0,037	0,43	03	03	03	0,06	0,43	03	03	03	0,09	0,32	03	03	03
		-	-	-	-	-	0,045	0,52	-	-	-	0,09	0,64	-	-	-	0,12	0,41	-	-	-
63	Ø11x23	-	-	-	-	-	0,06	0,7	01	01	01	0,12	0,88	01	01	01	0,18	0,62	01	01	01
		-	-	-	-	-	0,09	1,1	-	-	-	0,18	1,30	-	-	-	0,25	0,86	-	-	-
71	Ø14x30	0,09	1,4	01	01	01	0,18	2,0	01	01	01	0,25	1,80	01	01	01	0,37	1,30	01	01	01
		0,12	1,8				0,25	2,8				0,37	2,50				0,55	1,90			
80	Ø19x40	0,18	2,5	00	00	00	0,37	3,9	00	00	00	0,55	3,70	00	00	00	0,75	2,50	00	00	00
		0,25	3,5				0,55	5,8				0,75	5,10				1,10	3,70			
90 S	Ø24x50	0,37	5,3	00	00	00	0,75	8,0	0	00	00	1,10	7,50	0	00	00	1,50	5,00	00	00	00
90 L	Ø24x50	0,55	7,9	0	00	00	1,10	12	0	0	0	1,50	10	00	00	00	2,20	7,40	0	00	00
100 L	Ø28x60	0,75	11	0	0	0	1,50	15	0	0	0	2,20	15	0	0	0	3,00	9,80	0	0	0
		1,10	16									3,00	20				3,00	9,80			
112 M	Ø28x60	1,50	21	0	0	0	2,20	22	0	0	0	4,00	27	1	0	0	4,00	13	0	0	0
132 S	Ø38x80	2,20	30	1	1	1	3,00	30	1	1	1	5,50	36	1	1	1	5,50	18	1	1	1
		-	-	-	-	-	-	-	-	-	-	-	-	-	-	-	-	7,50	25	-	-
132 M	Ø38x80	3,00	40	1	1	1	4,00	40	1	1	1	7,50	49	1	1	1	-	-	-	-	-
160 M	Ø42x110	4,00	54	2	2	2	7,50	75	2	2	2	11,00	72	2	2	2	11,00	35	2	2	2
		5,50	74									15,00	19				15,00	60			
160 L	Ø42x110	7,50	100	2	2	2	11,00	109	2	2	2	15,00	98	2	2	2	18,50	60	2	2	2
180 M	Ø48x110	-	-	-	-	-	-	-	-	-	-	18,50	121	2	2	2	22	71	2	2	2
180 L	Ø48x110	11,00	145	3	2	2	15,00	148	3	2	2	22	148	3	2	2	-	-	-	-	-
200 L	Ø55x110	15,00	198	4	3	3	18,50	181	4	3	3	30	196	4	3	3	30	97	3	3	3
		-	-	-	-	-	22,00	215									37	120			
225 S	Ø55x110 Ø60x140	18,50	244	4	3	3	-	-	-	-	-	37	240	4	3	3	-	-	-	-	-
				4	4	4								4	4	4					
225 M	Ø55x110 Ø60x140	22	290	4	3	3	30	293	4	3	3	45	292	4	3	3	45	145	3	3	3
				4	4	4			4	4	4			4	4	4					
250 M	Ø60x140 Ø65x140	30	392	6	5	4	37	361	6	5	4	55	356	6	4	4	55	177	4	4	4
				6	5	5			6	5	5			5	5						
280 S	Ø65x140 Ø75x140	37	483	6	6	5	45	438	6	5	5	75	484	6	5	5	75	241	5	5	5
280 M	Ø65x140 Ø75x140	45	587	6	6	6	55	535	6	6	5	90	581	6	6	6	90	289	5	5	5
									6	6	6								5	6	6
315 S	Ø65x140 Ø80x170	55	712	8	7	6	75	727	8	7	6	110	707	8	7	6	110	353	6	5	5
									-	-	-						-	-	-	6	6
315 M	Ø65x140 Ø80x170	75	971	8	7	7	90	873	8	7	7	132	849	8	7	7	132	423	7	6	5
									8	7	7						7	7	7	7	6
315 L	Ø65x140 Ø80x170 Ø85x170	90	1170	8	8	7	110	1070	8	8	7	160	1030	8	8	7	160	513	7	6	5
		110	1420	8	8	8	132	1280	8	8	7	200	1290				200	641	7	6	6
		132	1710	10	8	8	160	1550	8	8	7	-	-				-	-	-	-	-
315	Ø65x140 Ø85x170	160	2070	10	8	8	200	1930	10	8	8	250	1600	8	8	7	250	802	8	7	7
		200	2580	-	10	8	250	2410	10	8	8	315	2020				315	1010	8	8	7
355	Ø75x140 Ø95x170	-	-	-	-	-	-	-	-	-	-	355	2280	9	8	8	355	1140	8	8	7
		250	3220	-	10	10	315	3040	-	10	8	400	2570	-	10	8	400	1280	8	8	7
		315	4060	-	-	-	400	3850	-	-	-	500	3210	-	10	10	500	1600	8	8	7
400	Ø80x170 Ø110x210	355	4570	-	-	-	450	4330	-	-	-	560	3580	-	-	-	560	1790	8	8	8
		400	5150	-	-	-	500	4810	-	-	-	630	4030	-	-	-	630	2020			

■ Only for GAS/SG-AL version (page 33)

NOTES ■

• For the choice of the coupling, is considered a safety factor of 1,5 on the nominal torque and an ambient temperature of 27 °C

GAS/SG & GAS - backlash free and standard jaw coupling: additional information

APPLICATION EXAMPLE

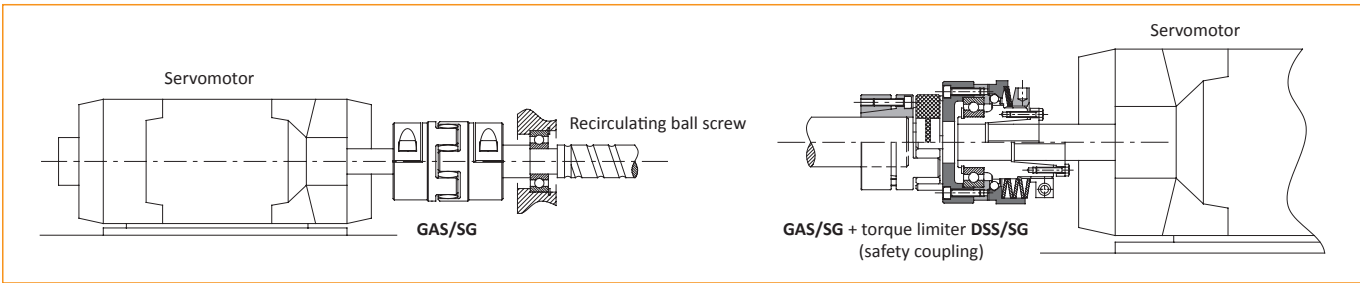

DIMENSIONING

For pre-selection of the coupling's size you can use the generic formula indicated on page 6. Having established the coupling's size to be used, it is possible to make other checks considering further parameters:

$$C_{nom} > C_{mot} \cdot f_T \cdot f_R$$

Dove:

- C_{nom} = theoretic nominal torque of the coupling [Nm]
- C_{mot} = nominal torque motor side [Nm]
- C_{max} = maximum torque of the coupling [Nm]
- C_{SU} = static torque user side [Nm]
- C_{SM} = static torque motor side [Nm]
- f_A = starting frequency factor
- f_R = rigidity factor
- f_T = thermic factor
- J_{mot} = inertia motor side [Kgm²]
- J_{uti} = inertia user side [Kgm²]
- K = shock factor

$$C_{max} = C_{SM} \cdot \frac{J_{uti}}{J_{mot} + J_{uti}} \cdot K \cdot f_T \cdot f_A + C_{mot} \cdot f_T \cdot f_R$$

Dove:

- C_{alt} = alternate system torque [Nm]
- C_{nom} = theoretic nominal torque of the coupling [Nm]
- f_F = resonance factor
- f_R = rigidity factor
- f_T = thermic factor
- M = coefficient of material

$$C_{nom} = C_{SU} \cdot \frac{J_{uti}}{J_{mot} + J_{uti}} \cdot K \cdot f_T \cdot f_A + C_{mot} \cdot f_T \cdot f_R$$

Dove:

- C_{alt} = alternate system torque [Nm]
- C_{nom} = theoretic nominal torque of the coupling [Nm]
- f_F = resonance factor
- f_R = rigidity factor
- f_T = thermic factor
- M = coefficient of material

$$C_{nom} > \frac{1}{M} \cdot C_{alt} \cdot f_F \cdot f_T \cdot f_R$$

Dove:

- C_{alt} = alternate system torque [Nm]
- C_{nom} = theoretic nominal torque of the coupling [Nm]
- f_F = resonance factor
- f_R = rigidity factor
- f_T = thermic factor
- M = coefficient of material

Coefficient of material (M)
 0,25 = aluminium
 0,35 = steel

Resonance factor (f_F)
 1 = frequency < 10
 $\sqrt{f/10}$ = frequency > 10

Rigidity factor (f_R)
 2÷5 = positioning system
 3÷8 = tool machines
 >10 = turn indicator

Shock factor (K)
 1 = light shock
 1,4 = medium shock
 1,8 = hard shock

Thermic factor (f_T)
 1 = -30 ÷ +30 °C
 1,2 = +40 °C
 1,4 = +60 °C
 1,8 = +80 °C

Starting frequency factor (f_A)
 1 = 0 ÷ 100 starting each hour
 1,2 = > 100 ÷ 200 " "
 1,4 = > 200 ÷ 400 " "
 1,6 = > 400 ÷ 800 " "
 1,8 = > 800 ÷ 1600 " "

Completed and verified the choice of the coupling respect the torque to be transmitted, it is necessary to consider the flexibility, comparing the misalignment allowed by the type of coupling chosen with the real ones provided by the shafts to be connected. If simultaneously present at all types of misalignment, it is necessary that the sum as a percentage of the maximum value does not exceed 100%, according to the graphic 1.

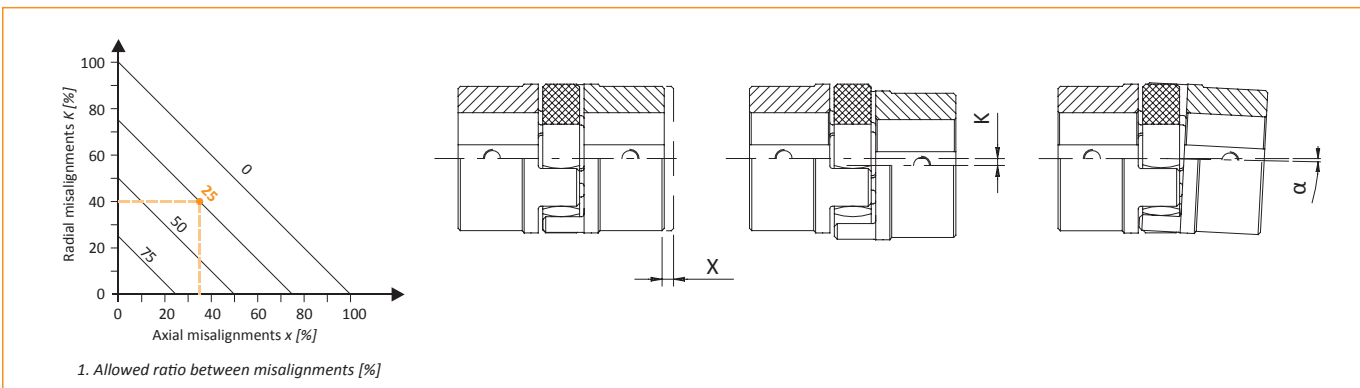

GAS/SG & GAS - backlash free and standard jaw coupling: additional information

FITTING

This coupling does not require particular procedures for assembly. It can be assembled both vertically and horizontally.

- 1) Achieve radial and axial alignments as precisely as possible, in order to have maximum absorption of possible misalignments and life of the coupling.
- 2) Assemble the two half-hubs on the shafts. Check that the external parts of the two shafts do not exceed the relevant half-hub's surface (quote "N") and fix this one to the shaft with its relevant fixing system.
- 3) Assemble the elastomeric element on one half-hub and close the other inserting the relevant teeth into the elastomeric element, being careful to respect the distance of the two half-hubs indicated on the catalogue, quote "P".

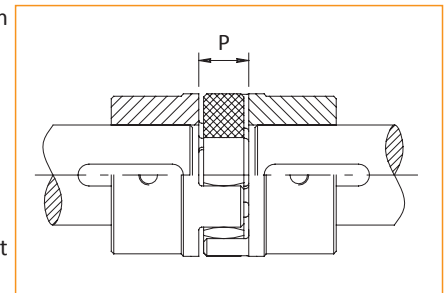

In case of connection by clamp locking or locking assemblies, tighten the relevant screws progressively up to the tightening torque indicated in the catalogue, using a cross sequence.

ORDER EXAMPLE OF COMPLETE COUPLING

JAW COUPLING									
Model	Material	Size	Version	Bore 1	Locking type bore 1	Bore 2	Locking type bore 2	DBSE / L _{tot}	Elastic element
GAS	ST	GR.4	M1-M1	bore Ø40 H7	B1	bore Ø40 H7	B1	-	Red spider 98 Sh-A

Material		Size	Version	Locking type		Elastic element	
ST	steel	from 04 to 10	M1-M1	see hub connection type list at page 4		For GAS - GAS/DBSE	
AL	aluminium		M1-M1L			yellow spider 92 Sh-A	
SS	stainless steel		M1-M2		red spider 98 Sh-A	For GAS/SG - GAS/SG/DBSE	
			M1-F		green spider 64 Sh-D	yellow spider SG 92 Sh-A	
			M1L-M1		red spider SG 98 Sh-A	green spider SG 64 Sh-D	
			M1L-M1L				
			M1L-M2				
			M1L-F				
			M2-M1				
			M2-M1L				
			M2-M2				
			M2-F				
			F-M1				
			F-M1L				
			F-M2				
			F-F				

Model	
GAS	jaw coupling
GAS/SG	backlash free jaw coupling
GAS/DBSE	jaw coupling with spacer
GAS/SG/DBSE	backlash free jaw coupling with spacer

In case of GAS/DBSE & GAS/SG/DBSE model indicate the length or spacer "DBSE" or total coupling length "L_{tot}".
 Example DBSE = 250mm / L_{tot} = 300mm

ORDER EXAMPLE OF INDIVIDUAL COMPONENTS

INDIVIDUAL COMPONENTS OF JAW COUPLING				
Component	Material	Size	Bore H7	Locking type
Hub GAS M1	ST	Size 4	Bore Ø54 H7	C

Component	Material	Size	Locking type
hub GAS M1	ST steel	from 04 to 10	see hub connection type list at page 4
hub GAS M1L	AL aluminium		
hub GAS M2	SS stainless steel		
flangie GAS F			
hub GAS/SG M1			
hub GAS/SG M1L			
hub GAS/SG M2			
yellow spider 92 Sh-A			
red spider 98 Sh-A			
green spider 64 Sh-D			
yellow spider SG 92 Sh-A			
red spider SG 98 Sh-A			
green spider SG 64 Sh-D			